

REVISIONS				
ZONE	REV.	DESCRIPTION	DATE	REV. BY

4X 3/4-10 UNC LIFT POINT

DIM "A"

18

2X MOTOR TOP COVER ACCESS

4X SHOCK STOP COVER ACCESS

6X AIR BEARING COVER ACCESS

4X SHIPPING BOLT

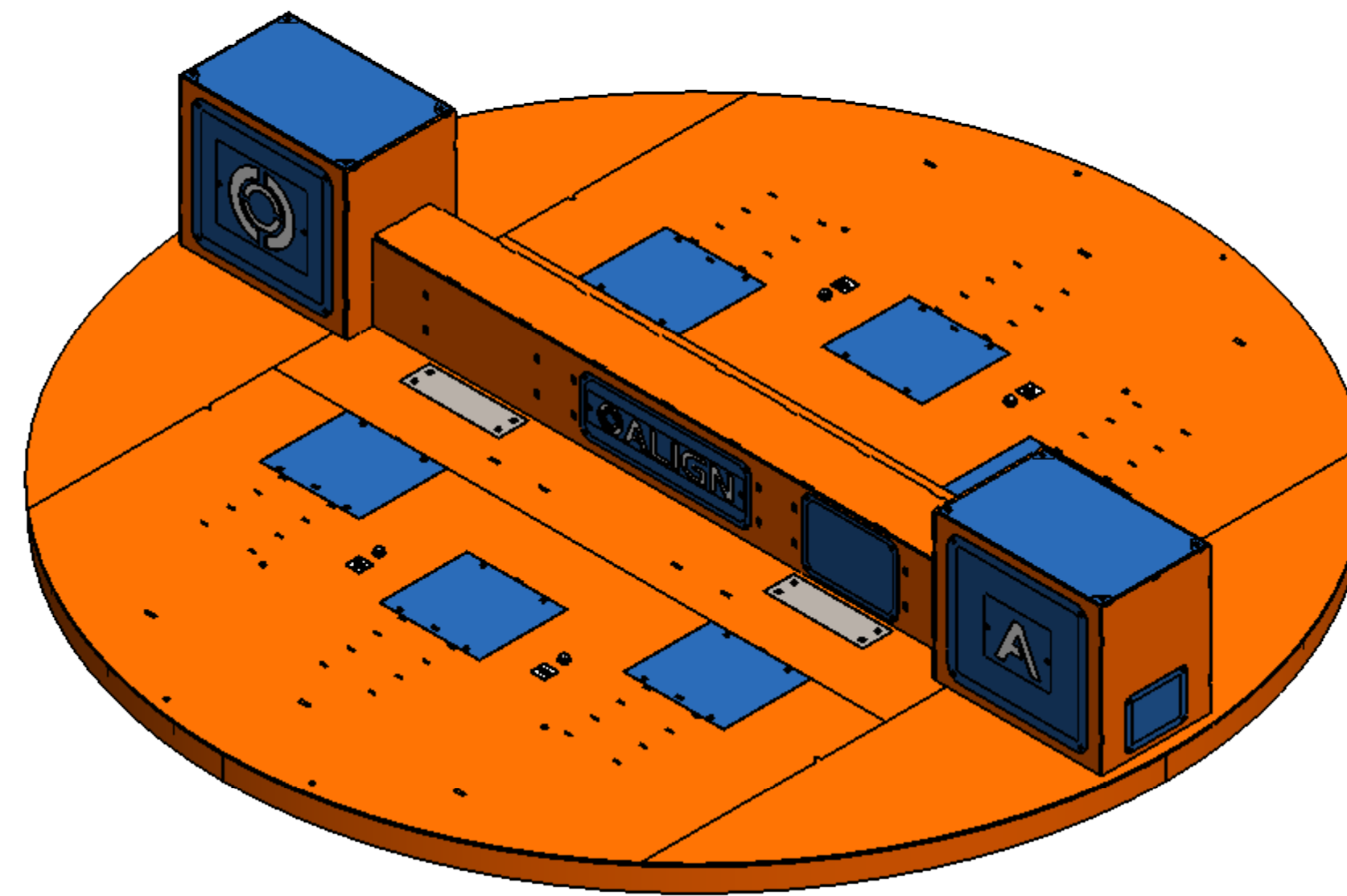

SPECIFICATIONS:

- CAPACITY - 10,000 LBS TOTAL / 5,000 LBS PER SIDE
- TABLE SIZE - SEE TABLE
- AIR SUPPLY - 30-75 SCFM @ 80 PSI (CLEAN AND DRY)
- ELECTRICAL SUPPLY - 480 3PH VAC
- DRIVE SIZE - 2X 7.5 HP 3HP GEAR MOTOR
- PAINT - ALIGN SPEC. COLORS / AIR DRY ENAMEL PAINT

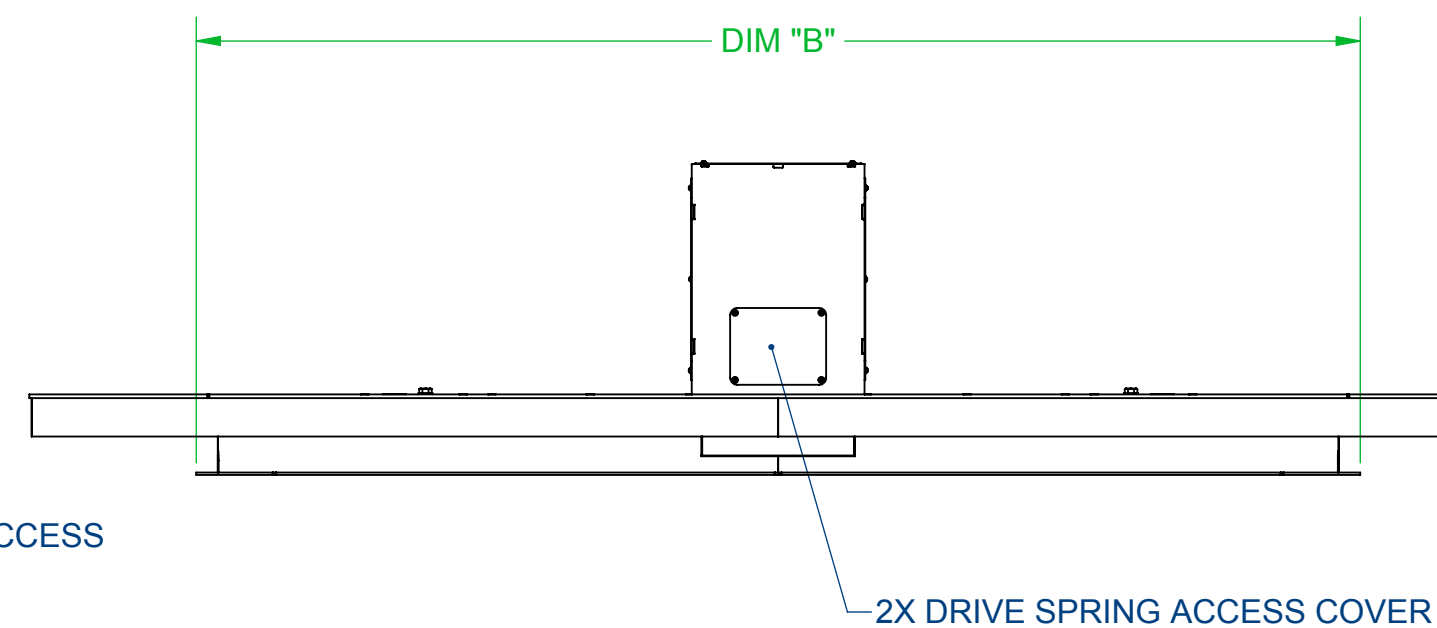
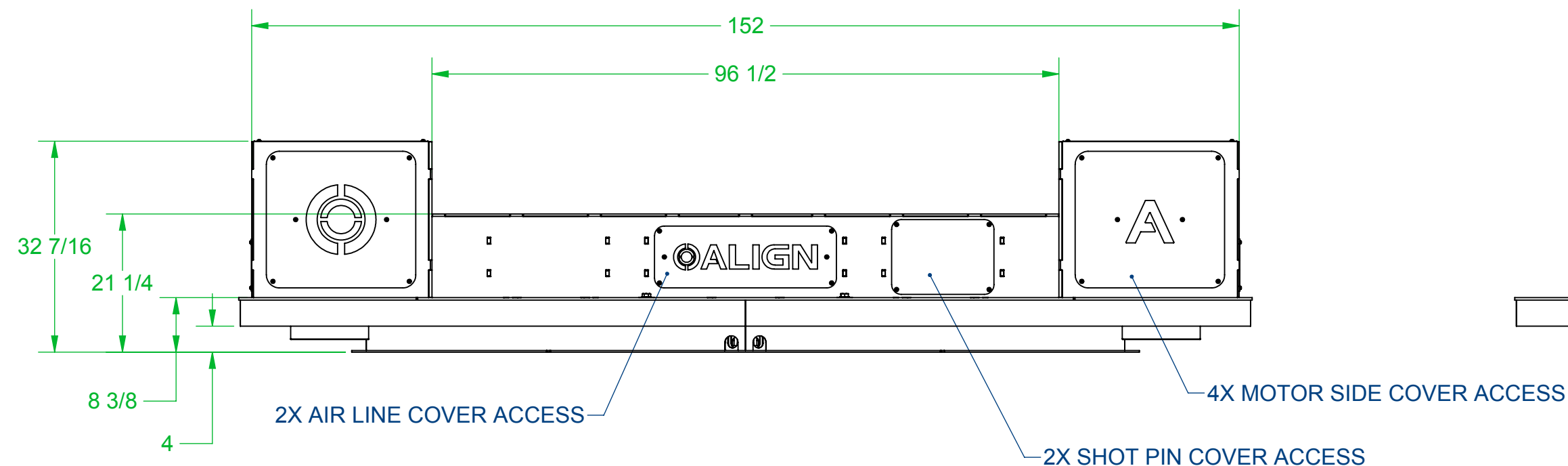

Part Number	Top Diameter DIM "A" (in)	Base Diameter DIM "B" (in)	Tabletop Shape	Capacity Total / Per Side (lbs)	Cycle Time* (sec)	Air Flow** (SCFM)	Weight*** (lbs)	Max. Rack Size Option #1 (in)	Max. Rack Size Option #2 (in)
AX030-0108	108	72	ROUND	10,000 / 5,000	6	60	5,300	96 x 28	44 x 36
AX030-0120	120	84	ROUND	10,000 / 5,000	6.5	60	5,600	108 x 40	56 x 48
AX030-0132	132	96	ROUND	10,000 / 5,000	6.5	75	6,000	120 x 52	68 x 60
AX030-0144	144	108	ROUND	10,000 / 5,000	7	75	6,500	132 x 64	80 x 72
AX030-0156	156	120	ROUND	10,000 / 5,000	7	75	7,000	144 x 76	92 x 84
AX031-XXXXXX	XXX	YYY	RECTANGULAR	10,000 / 5,000	TBD	TBD	TBD	TBD	TBD

* CYCLE TIME FOR 180° ROTATION. MAY VARY DEPENDING ON LOAD SIZE. EXCLUDES DEFLATION TIME (APPROX. 0.8 SECONDS)
 ** APPROXIMATE AIR FLOW AT 80 PSI
 *** APPROXIMATE WEIGHT, WILL VARY BASED ON TABLETOP SIZE
 **** CUSTOM RECTANGULAR TOP OPTION AVAILABLE, CONTACT SALES FOR MORE INFORMATION

DIMENSIONS FOR REFERENCE ONLY. TOLERANCE BLOCK DOES NOT APPLY.

DISCARD ALL DRAWINGS AND/OR BILL OF MATERIALS ISSUED PRIOR TO
8/1/2019
 USE PRINT WITH THE LATEST DATE FOR PRODUCTION
 ENGR. APPROVAL _____

UNLESS OTHERWISE SPECIFIED DIMENSIONS ARE IN INCHES TOLERANCES ARE:		WORK ORDER #	ROUTING		2230 Brush College Rd Decatur, IL 62526 www.alignproduction.com sales@alignprod.com Phone: 217.423.6001
FRACTIONS: ± 1/16	DECIMALS: .X ± .06	DRAWN	BME		
ANGULAR: ± 1°	.XX ± .02 .XXX ± .005	TITLE		HIGH SPEED TURNTABLE / 10K CAPACITY / SALES	
DO NOT SCALE DRAWINGS	TOTAL WT. 0.00 lbs	SHEET 1 OF 1	SIZE C	SCALE 1:18	DRAWING NO. B30-0001
					REV. -01